

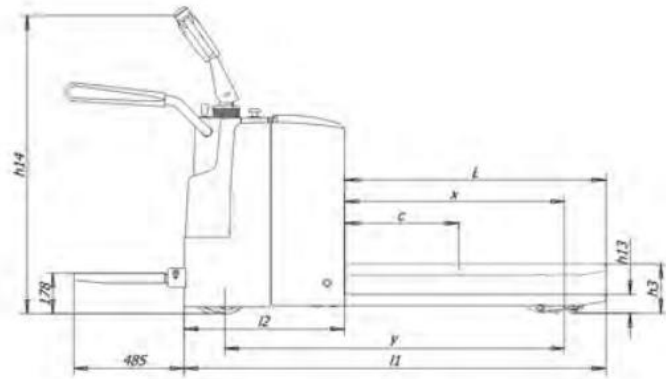

CBDN all-electric pallet truck, also known as all-electric pallet truck, is suitable for heavy-duty and long-term cargo transfer conditions, which can greatly improve the efficiency of cargo handling and reduce labor intensity. It is powered by battery, adopts AC stepless speed controller, hydraulic. The power unit is lifted, the joystick is centrally controlled, and the standing driving is performed.

- Small body, can work in narrow passages, and can enter the elevator with full load;
- Humanized design handle, all functions can be realized through handle buttons;
- Specially designed AC drive motor to provide stronger power.

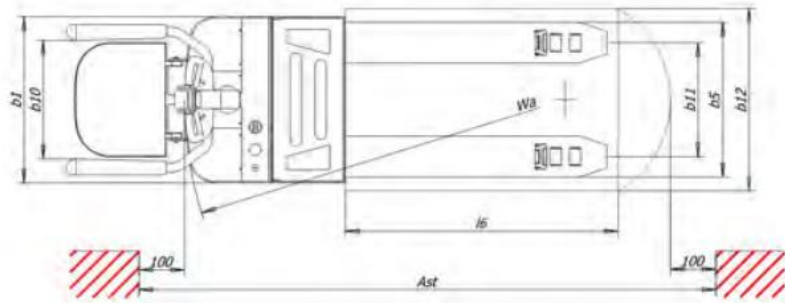

Model		CBDN20	CBDN25
power type		Battery	
Operation Type		Stand on	Stand on
Rated Capacity	kg	2000	2500
Load Center C	mm	600	600
Front Overhang X	mm	967	967
Wheelbase Y	mm	1520	1520
Weight(with battery)	kg	710	715
Tire		Polyurethane	Polyurethane
Tyre size, front	mm	φ230×75	φ230×75
Tyre size, rear	mm	φ80×70	φ80×70
Additional wheels	mm	φ130×55	φ130×55
Track width, rear (b11)	mm	390/500	390/500

Track width, front (b10)	mm	498	512
Max lifting height (h3)	mm	200	200
Total Height (h14)	mm	1360	1360
Fork ground clearance (h13)	mm	85	85
Overall Length (L1)	mm	1980	1980
Overall Width (b1)	mm	730	730
fork size H/W/L	mm	65/160/1200	65/160/1200
Fork width (b5)	mm	570/680	570/680
Turning radius (wa)	mm	1530	1530
Travel Speed (laden/unladen)	km/h	5/6	5/6
lifting speed(laden/unladen)	mm/s	25/30	25/30
lowering speed(laden/unladen)	mm/s	30/25	30/25
Gradability(laden/unladen)	%	6/15	6/15
Drive motor	kw	1.5	1.5
Lift Motor	kw	2.2	2.2
Battery voltage	V	24	24
Battery capacity	Ah	210	210
Noise	dB	<70	<70